

## 962 Hydro LED - 1-10 Dimmable



The high technological expertise achieved by the Disano Group in both the design and industrial manufacturing of lighting fixtures has resulted in the creation of a new watertight LED fixture. New Hydro LED features a modern design that blends well into any type of setting.

Housing: injection moulded, in grey polycarbonate, shatter-proof, UV-stabilised, highly resistant to mechanical impacts thanks to the reinforced structure with internal ribbing. Diffuser: injected moulded in polycarbonate with internal ribbing for greater lighting control, in V2 self-extinguishing, UV-stabilised material; its smooth outer finish makes cleaning easier and increases lighting efficiency. Equipped with stainless steel screw clamping.

Reflector: in galvanised steel, previously stone-enamelled with UV-stabilised polyester resin. Clamping device manufactured directly onto the housing.

Dimensions: L 1260mm - 102mm - 120mm Wiring: rigid cable diam. 0.5 SQmm. PVC\_HT sheathing resistant to 90°C. according to EN 50525-2-31.

Standard supply: eco-friendly and anti-aging expanded polyurethane injected gasket. The fixing brackets for ceiling and suspension mounting are in stainless steel. Socket-plug connector. The fixture is secured to the fixing brackets through quick connectors.

Regulations: manufactured in compliance with EN60598-1, EN60598-2-1.

Degree of protection: pursuant to EN60598-1.

Photo biological safety class: exempt

Power factor:  $\geq 0.95$  Luminous flux maintenance after 50.000 hrs: L80B20.

Low Flicker Risk

Ambient temperature: -30°C to +40°C

EM Ambient temperature: +5°C to +40°C

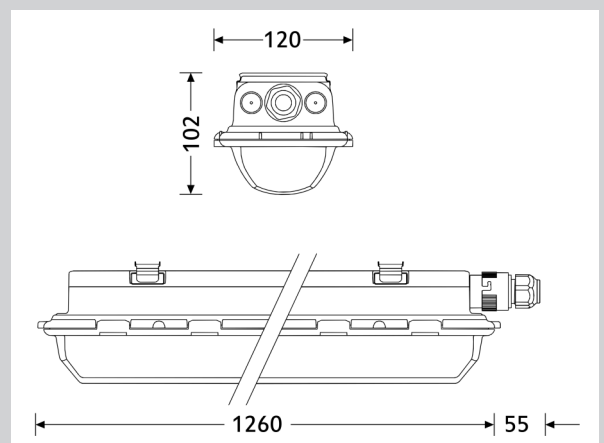

**[www.epaproducts.co.uk](http://www.epaproducts.co.uk)**

