

INSTALLATION

How to connect the ventilation input

Connect the ventilation input provided as shown in the diagram.

How to connect response potentiometer :

Connect the response potentiometer of each value (max 10.000 ohm, recommended 1 Kohm type) and connect the terminals **7-8**.

For remote connections use a standard 0.5-square millimetre two-poles wire for each sensor, taking great care over the connections, by insulating and sealing the joins carefully.

How to connect the line

Connect line on terminals **L-N**.

How to connect the contacts

Connect terminals on the terminal block (contacts up to 4AMP.AC1) to the loads as shown in the diagram).

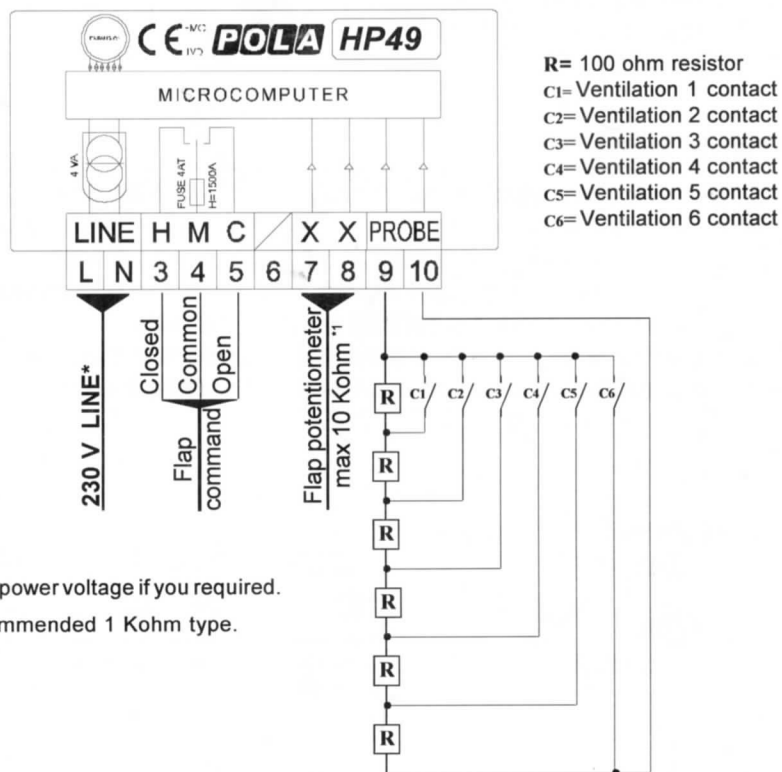

* Other power voltage if you required.

*1 Recommended 1 Kohm type.

HP49

SL 6.0

Associative flap with feedback

Handbook



RUN MODE

In normal condition on display appears % flap position

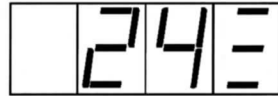

Example with % flap position = 24%

COST PROGRAMMING (System constants)

These settings refer to the mode of operation of the system and must be made on initial start-up. Press **-/+** together for at least one second: the message **C.O.S.t.** will be displayed.

Press then repeatedly **ENTER** until interested, variable's message is displayed (see table below) : variable value and relative message will be displayed. Press **+** or **-** to set a new value and then **ENTER** to confirm.

The next system constant will then appear.

You can press **ENTER** for at least two seconds to escape and return to the *Run Mode*.

Mess.	Value	Meaning	Note
<i>n.POS</i>	6	Number of input ventilation step	*1
<i>POS.0</i>	0	Flap % position at step 0 ventilation	*2
<i>POS.1</i>	0	Flap % position at step 1 ventilation	*2
<i>POS.2</i>	0	Flap % position at step 2 ventilation	*2
<i>POS.3</i>	0	Flap % position at step 3 ventilation	*2
<i>POS.4</i>	0	Flap % position at step 4 ventilation	*2
<i>POS.5</i>	0	Flap % position at step 5 ventilation	*2
<i>POS.6</i>	0	Flap % position at step 6 ventilation	*2

*1) This setting corresponds to the number of ventilation steps that are connected with the **9-10** terminals (see *Installation*).

*2) Program only the number of unit position (that correspond to the *n.POS* setting).

FLAP POTENTIOMETER INITIALIZATION PROCEDURE (Init)



A response potentiometer of each value must be applied to the flap motor. Having done this, proceed as follows to record the potentiometer values. Press **ENTER** key for at least 3 seconds:

When *Init* message will be displayed for more than one second release **ENTER** key: the processor closes the flap (light **CLOSE** flashes) and the potentiometer resistance value is displayed.

When the flap have completely closed, press **ENTER** key to record the value. at this point the processor opens the flap (light **OPEN** flashes) and the potentiometer resistance value is displayed.

When the flap has completely opened, press **ENTER** key to record the value. The processor then returns automatically to the Run mode.

PRESET PROGRAMS

On delivery this processor is just programmed with the following (variable) settings. To return to these settings at any time:

Power off the processor, press **ENTER** key and keep it pressed giving power on: after 2 seconds *boot* message will be displayed (release now **ENTER** key).

The **COST** values are shown in **COST** paragraphs.

"HAND" MODE

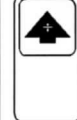

During some start-up conditions may be useful to work in "hand" mode. Power off the processor, press **+** key and keep it pressed giving power on: *HAnd* message will be displayed (release now **+** key).

Push **+** until is displayed the required number to be handed (see table relays "N° Relay") and push **ENTER** to active the relay.

Pushing again **+** to increase another relay number previous relay is deactivated.

You can press **ENTER** for at least two seconds to escape and return to the *Run Mode*.

STATE INDICATION LAMPS

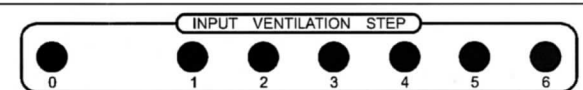

These lamps show the condition of the input's signal of the ventilation.

Lamp.	Meaning	N° Relay	Contactts
CLOSE	Close (Heat) On	1	3-4
OPEN	Open (Cool) On	2	4-5